

The Type 42 and 43 Gate Valve is an industry accepted, field proven gate valve, which provides the reliability and interchangeability, needed in the competitive market today. The Type 42 and 43 Gate Valves are bi-directional sealing and utilize a non-rising stem, making it ideally suited for drilling manifold and production operations. Materials and trims are available for all operating conditions.

Type 42 and 43 Gate Valves are available for operating pressures up to 20,000 psi, which can meet all API 6A (ISI 10423) PSL levels regulations. The type 42 and 43 Gate Valve can be equipped with hydraulic actuators for manifold or subsea service. The Type 42 and 43 Gate Valves are currently being used in all areas of the world where oil and gas is produced. The Type 42 and 43 Gate Valve has full component interchangeability with the industry proven Type FL and FLS Gate Valve.

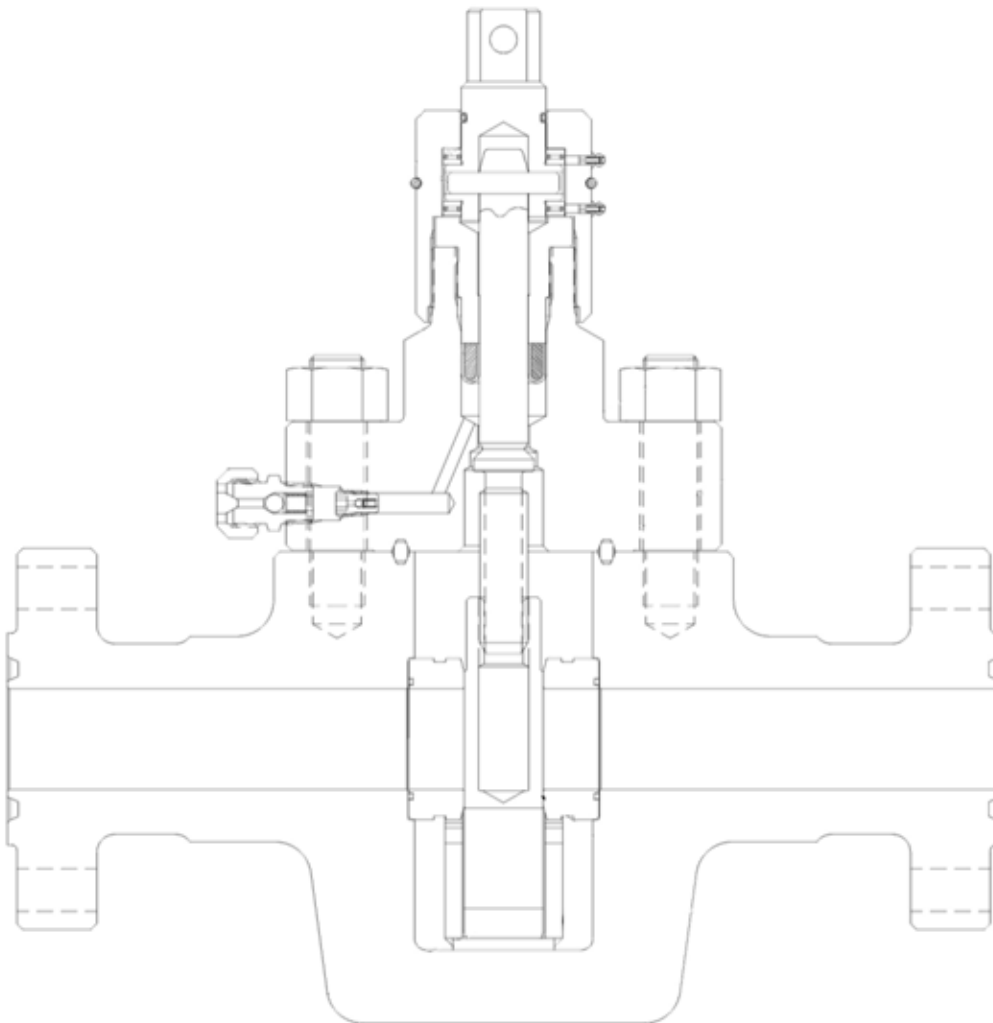

TYPE 42-43

GATE VALVE

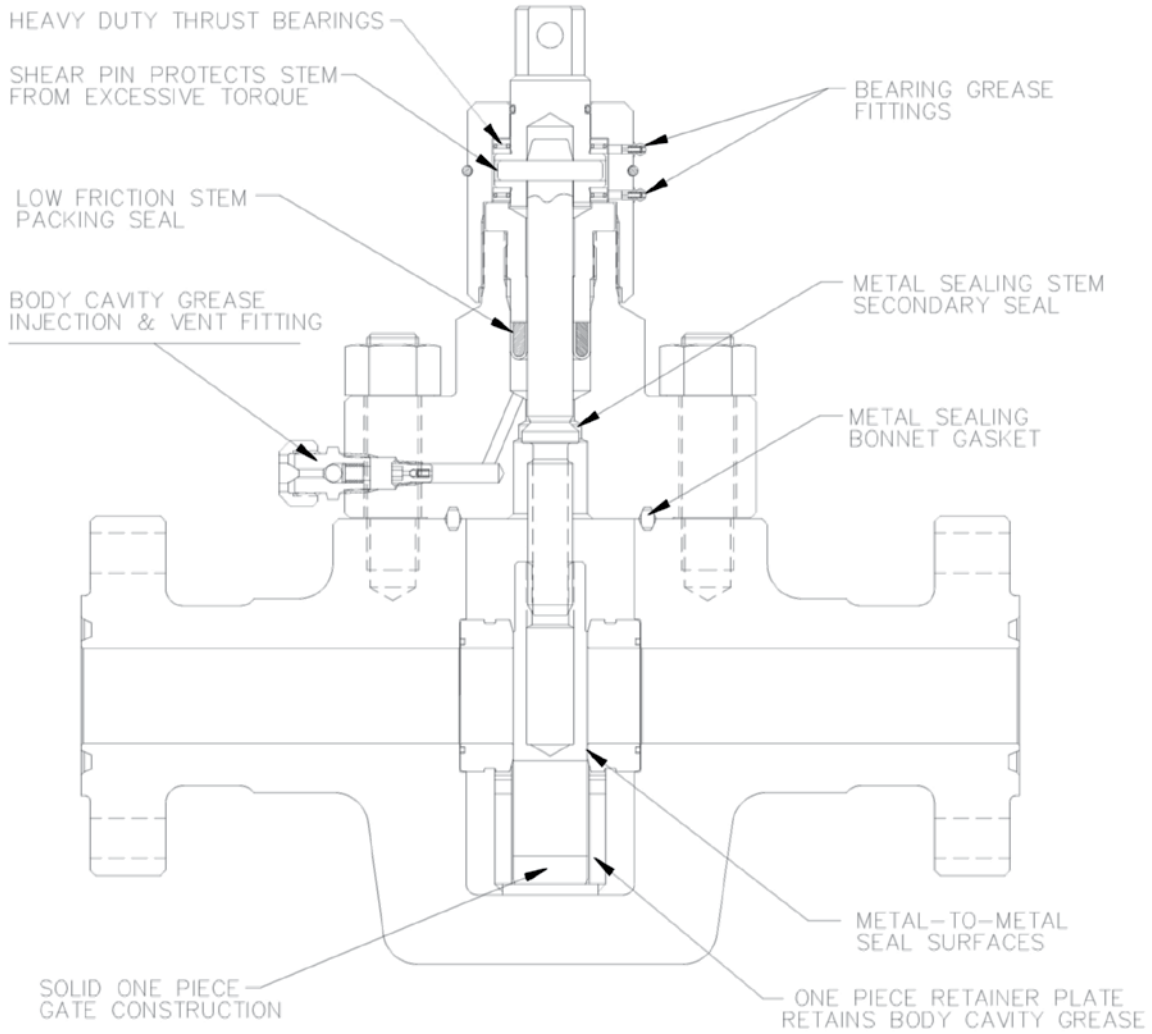

MANUAL GATE VALVE

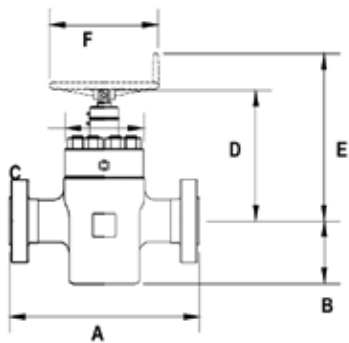

HYDRAULIC GATE VALVE

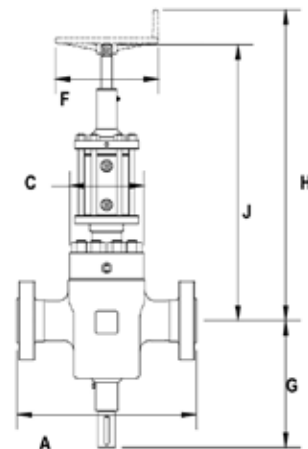

TYPE 42-43

GATE VALVE

DIMENSIONAL DATA FOR API 3000 PSI W.P. (6000 PSI TEST)

Nom. Bore Size	API Ring Joint	A	B	C	D	E	F	G	H	J	Wt. Lbs. (Man)	Wt. Lbs. (Hyd.)
2-1/16"	R-24	14.62	5.62	6.75	13.00	18.88	14.00	14.25	34.25	28.38	180	275
2-9/16"	R-27	16.62	6.50	7.62	13.81	19.68	14.00	15.94	37.12	31.25	250	350
3-1/8"	R-31	17.12	7.38	7.50	16.81	22.68	14.00	17.25	41.38	35.50	280	400
4-1/16"	R-37	20.12	9.12	10.50	18.44	24.31	18.00	19.75	45.88	40.00	450	550
6-1/8"	R-45	24.12	12.75	12.75	22.75	28.62	24.00	25.88	59.18	53.31	910	1100

DIMENSIONAL DATA FOR API 5000 PSI W.P. (7500 PSI TEST)

Nom. Bore Size	API Ring Joint	A	B	C	D	E	F	G	H	J	Wt. Lbs. (Man)	Wt. Lbs. (Hyd.)
2-1/16"	R-24	14.62	5.62	7.00	15.12	21.00	14.00	14.25	36.38	30.50	180	280
2-9/16"	R-27	16.62	6.50	8.18	15.94	21.81	14.00	15.94	38.88	33.00	255	360
3-1/8"	R-35	18.62	7.38	9.25	16.81	22.68	18.00	17.25	41.38	35.50	360	430
4-1/16"	R-39	21.62	9.12	10.81	18.44	24.31	18.00	19.75	45.88	40.00	545	650
6-1/8"	R-46	29.00	12.75	14.12	22.75	28.62	24.00	25.88	59.18	53.31	1090	1490

DIMENSIONAL DATA FOR API 10000 PSI W.P. (15000 PSI TEST)

Nom. Bore Size	API Ring Joint	A	B	C	D	E	F	G	H	J	Wt. Lbs. (Man)	Wt. Lbs. (Hyd.)
1-13/16"	BX-151	18.25	5.75	9.06	15.12	21.00	14.00	14.38	36.38	30.50	270	330
2-1/16"	BX-152	20.50	5.88	9.38	15.12	21.00	14.00	14.50	36.38	30.50	275	370
2-9/16"	BX-153	22.25	6.81	9.81	15.81	21.68	18.00	15.94	38.88	33.00	485	555
3-1/16"	BX-154	24.38	8.06	10.25	16.88	22.75	18.00	17.25	42.75	36.88	680	750
4-1/16"	BX-155	26.38	10.06	12.81	19.68	25.56	24.00	19.75	49.88	44.00	1060	1170
6-3/8"	BX-156	35.00	14.75	17.12	45.12	51.00	24.00				3500	

DIMENSIONAL DATA FOR API 15000 PSI W.P. (22500 PSI TEST)

Nom. Bore Size	API Ring Joint	A	B	C	D	E	F	G	H	J	Wt. Lbs. (Man)	Wt. Lbs. (Hyd.)
1-13/16"	BX-151	18	5.88	9.88	15.12	21.00	14.00	14.38	36.38	30.50	275	335
2-1/16"	BX-152	19	6.12	9.88	15.12	21.00	18.00	14.50	36.38	30.50	350	445
2-9/16"	BX-153	21	7.31	11.50	17.18	23.06	18.00	16.38	43.00	37.12	800	870
3-1/16"	BX-154	23.56	9.25	13.56	20.94	26.81	24.00	20.62	51.12	45.25	1065	1150
4-1/16"	BX-155	29	10.18	21.00	22.81	28.68	24.00				1300	

All dimensions in inches.